



The Natural Therapist

The official journal of the
Australian Natural Therapists Association (ANTA)

MEDIA PROFILE



IT'S YOUR CHOICE,
NATURALLY

THE NATURAL THERAPIST - ABOUT THE JOURNAL

'The Natural Therapist' is a high quality journal that gives you the opportunity to showcase your unique products and services to thousands of potential clients every four months. Each issue incorporates a range of leading natural therapies articles coupled with regular contributors from a variety of modalities: Acupuncture, Herbal Medicine, Nutrition, Naturopathy, Oriental Remedial Therapy and more.

We aim to present informative reading, written by people within the profession for people who like to make informed decisions. Our magazine offers respectful forums for the education and empowerment of all people.



DISTRIBUTION

Over 10,000 copies of 'The Natural Therapist' journal are distributed nationally to natural therapy practitioners every 3 - 4 months. With a rapidly increasing membership our journal is constantly growing in popularity offering advertisers a fantastic opportunity to add to their customer base.

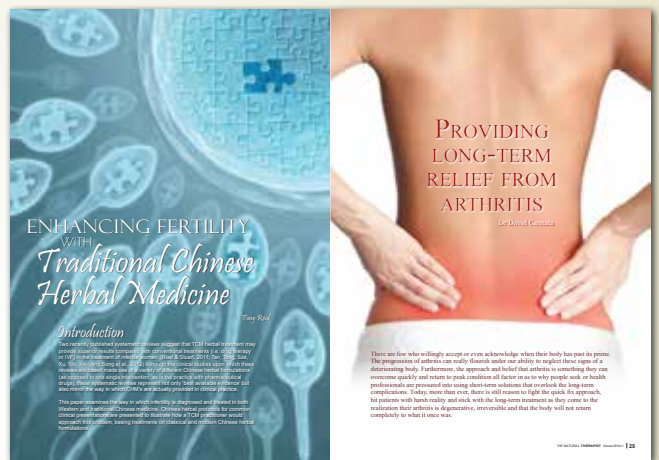

PRINT EDITION RATES

FULL COLOUR DISPLAY AD	Ad Sizes	3 issues or more [^]	Casual Rate	2 Pages / Issue 3 issues
FP Inside Front Cover *	210mm x 297mm	\$795	\$1035	
FP Inside Back Cover *	210mm x 297mm	\$795	\$1035	
FP Back Page *	210mm x 297mm	\$795	\$1035	\$1272
FP Centre Page ad (best possible position)	210mm x 297mm	\$730	\$945	
1/2 Page ad	187mm x 130mm	\$415	\$520	
1/4 Page ad	125mm x 85mm	\$295	\$331	

* Subject to availability. Please confirm availability before booking.
[^] Must book for 3 editions. ^{^^} Multiple insertions price listed is per display ad.
 Rates include GST. Prices listed are per edition. Preferred positions subject to availability.

OUR PARTNERS

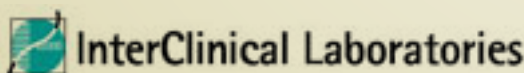

PRINT SPECIFICATIONS

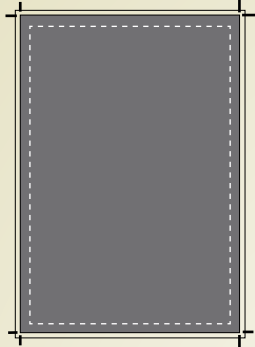
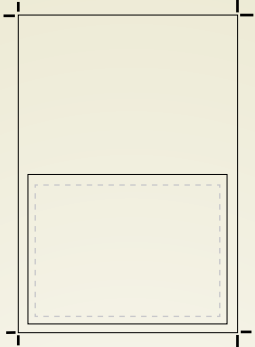
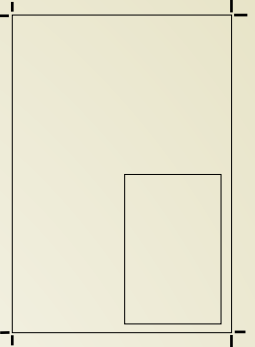
		
<p>Full Page FP Trim: 210mm W x 297mm H Bleed: 220mm W x 307mm H Type area: 185mm W x 268mm H</p>	<p>Half Page 1/2 H Trim: 187mm W x 130mm H Bleed: 193mm W x 136mm H</p>	<p>Quarter Page 1/4 H Trim: 85mm W x 125mm H</p>

MATERIAL REQUIREMENTS

FORMAT

Supplied electronically via:

- Email
- Quickcut - www.quickcut.com.au
- You Send It - www.hightail.com
- DVD/CD

GRAPHIC PROGRAMS

- Adobe InDesign CS3
- Adobe Photoshop CS3
- Adobe Illustrator CS3
- Adobe Acrobat PDF CS (v7.0)
- All files - Macintosh format
- All files - must be in CMYK mode (NOT RGB or Spot)
- Images are to be high resolution (300dpi) TIFF or if sending via email, JPG. Please use the lowest compression to achieve the highest quality image.
- All fonts are to be supplied or all text to be converted to outlines in Illustrator & InDesign files.
- PDF files must be 300dpi and fonts to be embedded.

PRINT EDITION SCHEDULE

MONTH	BOOKING	ARTWORK
March	First week in February	End of Second week in February
July	First week in June	End of second week in June
November	First week in October	End of second week in October
Please note: Dates are correct at time of printing and are subject to change.		

MEMBERS MAIL OUT

ANTA offers a mail-out service to our Members from external sources at a charge of \$2.20/member (this price includes the postage, labour and GST). The first step is to submit to ANTA, for approval, a sample of the material to be mailed out.

Once approval is granted, the material is to be forwarded to ANTA's National Administration Office in a sealed DL (Business Size) envelope marked with "Postage Paid Australia" in the top right hand corner.

Payment must be finalised prior to forwarding materials to ANTA.





REGULAR CONTRIBUTORS

Michael Weir

BA, LLB(Hons) UQ, LLM (Bond) Associate Professor School of Law, Bond University, Solicitor of the Supreme Court of Queensland, Author "Complementary Medicine - Ethics and Law" & "Alternative Medicine A New Regulatory Model"

Kerry Bone

BSc(Hons), Dip Phyto, Associate Professor School of Health UNE, ANTA Fellow, FNIMH, FNHAA, MCPP

Tony Reid

Dip TCM, Dip Ac (Hong Kong), Master TCM, Cert Clinical Practice (China), Author "Practitioners Clinical Guide - ESSENTIAL FORMULAS" & "Supplementary Clinical Guide - EMPIRICAL FORMULAS"

The Natural Therapist

The Natural Therapist is bought to you by the
Australian Natural Therapist Association.

PO Box 657, Maroochydore QLD 4558

P: 1800 817 577

F: 07 5409 8200

E: info@anta.com.au

W: www.australiannaturaltherapistsassociation.com.au

Contact

For all advertising enquiries

E: thenaturaltherapist@anta.com.au

Journal profile

Published: Quarterly - 3 issues per year Distribution:
10,000

Over 45 pages, perfect bound

Shelf life: 3 - 4 months

Demographic: Natural Therapists, Students, Colleges

IT'S YOUR CHOICE,

NATURALLY